

AVR 125 REAR-PANEL CONNECTIONS

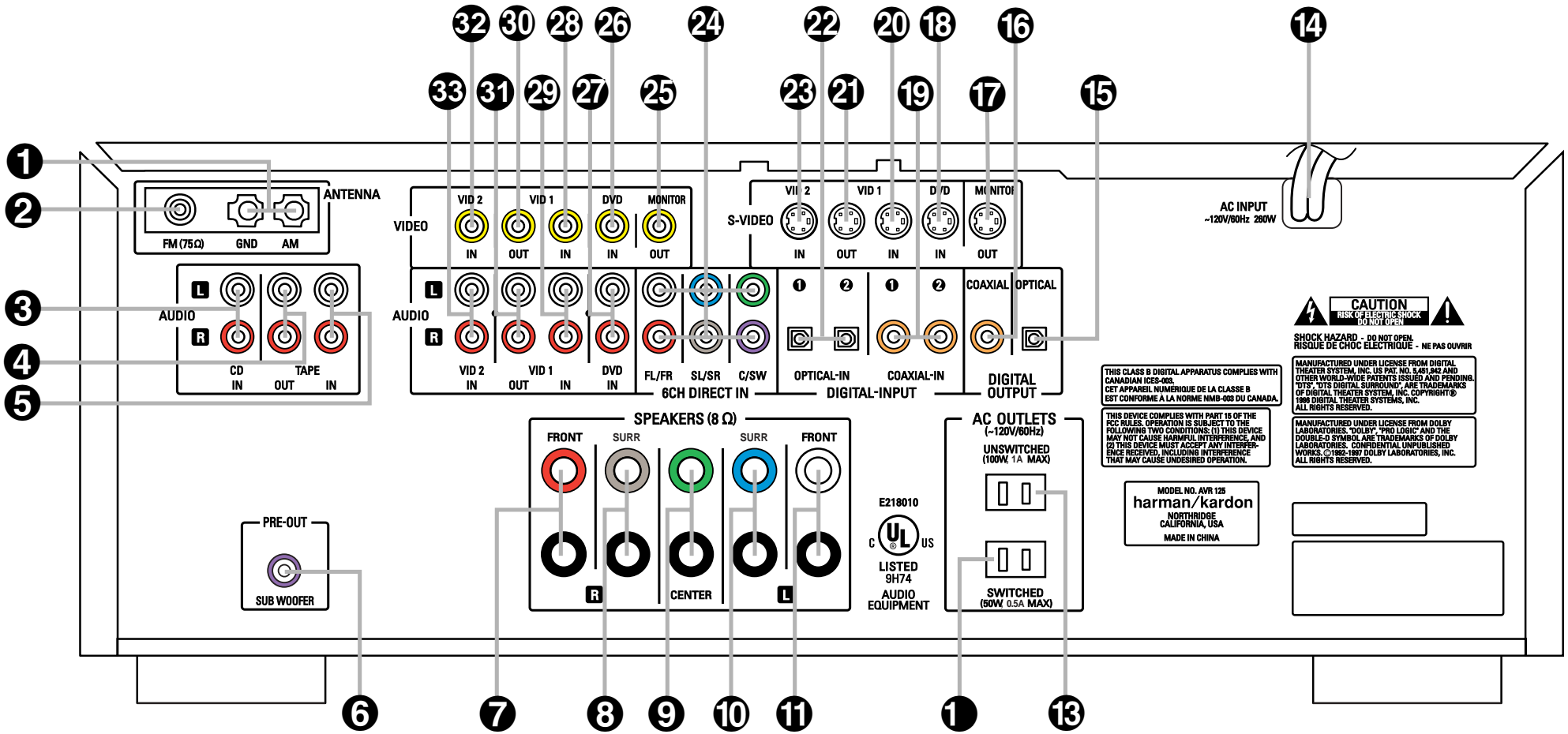

- | | | |
|-----------------------------|-----------------------------------|---|
| 1 AM Antenna | 1 Switched AC Accessory Outlet | 23 Video 2 S-Video Input |
| 2 FM Antenna | 13 Unswitched AC Accessory Outlet | 24 6-Channel Direct Inputs |
| 3 CD Inputs | 14 AC Power Cord | 25 Video Monitor Composite Video Output |
| 4 Tape Outputs | 15 Optical Digital Output | 26 DVD Composite Video Input |
| 5 Tape Inputs | 16 Coaxial Digital Output | 27 DVD Audio Inputs |
| 6 Subwoofer Output | 17 Video Monitor S-Video Output | 28 Video 1 Composite Video Input |
| 7 Front Speaker Outputs | 18 DVD S-Video Input | 29 Video 1 Audio Inputs |
| 8 Surround Speaker Outputs | 19 Coaxial Digital Inputs | 30 Video 1 Composite Video Output |
| 9 Front Speaker Outputs | 20 Video 1 S-Video Input | 31 Video 1 Audio Outputs |
| 10 Surround Speaker Outputs | 21 Video 1 S-Video Output | 32 Video 2 Composite Video Input |
| 11 Front Speaker Outputs | 22 Optical Digital Inputs | 33 Video 2 Audio Inputs |

NOTE: To assist in making the correct connections for multichannel input, output and speaker connections, all connection jacks and terminals are color-coded in conformance with the latest CEA standards as follows:

Front Left: White	Subwoofer: Purple
Front Right: Red	Digital Audio: Orange
Center: Green	Composite Video: Yellow
Surround Left: Blue	
Surround Right: Gray	

CAUTION
RISK OF ELECTRIC SHOCK
DO NOT OPEN

SHOCK HAZARD - DO NOT OPEN.
RISQUE DE CHOC ELECTRIQUE - NE PAS OUVRIR

THIS CLASS B DIGITAL APPARATUS COMPLIES WITH CANADIAN ICES-003.
CET APPAREIL NUMERIQUE DE LA CLASSE B EST CONFORME A LA NORME NMB-003 DU CANADA.

THIS DEVICE COMPLIES WITH PART 15 OF THE FCC RULES. OPERATION IS SUBJECT TO THE FOLLOWING TWO CONDITIONS: (1) THIS DEVICE MAY NOT CAUSE HARMFUL INTERFERENCE, AND (2) THIS DEVICE MUST ACCEPT ANY INTERFERENCE RECEIVED, INCLUDING INTERFERENCE THAT MAY CAUSE UNDESIRABLE OPERATION.

MANUFACTURED UNDER LICENSE FROM DIGITAL THEATER SYSTEM, INC. US PAT. NO. 5,481,842 AND OTHER WORLD-WIDE PATENTS ISSUED AND PENDING. "DTS" "DTS DIGITAL SURROUND" ARE TRADEMARKS OF DIGITAL THEATER SYSTEM, INC. COPYRIGHT © 1998 DIGITAL THEATER SYSTEMS, INC. ALL RIGHTS RESERVED.

MANUFACTURED UNDER LICENSE FROM DOLBY LABORATORIES. "DOLBY" "PRO LOGIC" AND THE DOUBLE-D SYMBOL ARE TRADEMARKS OF DOLBY LABORATORIES. CONFIDENTIAL UNPUBLISHED WORKS. ©1992-1997 DOLBY LABORATORIES, INC. ALL RIGHTS RESERVED.

MODEL NO. AVR 125
harman/kardon
NORTHBRIDGE
CALIFORNIA, USA
MADE IN CHINA